

Best Practice Guidelines

Filtration for Commercial Office Spaces



WWW.NAFHQ.ORG





Table of Contents

| | |
|--|----|
| Contributor Acknowledgement | 3 |
| About NAFA | 4 |
| NAFA Certifications | 5 |
| Purpose, Scope & Background & Challenge | 6 |
| NAFA Best Practice Recommendations (systems approach).... | 8 |
| NAFA Best Practice Recommendations (application approach)..... | 12 |
| Installation, Operation and Maintenance | 14 |
| COVID Special Section | 17 |
| Glossary | 18 |
| Bibliography | 19 |
| Copyright & Usage | 20 |

National Air Filtration Association (NAFA) Headquarters

1818 Parmenter Street, #300

Madison, WI 53562

www.nafahq.org

*Copyright © National Air Filtration Association 2023
Revised 2.26.2023. All rights reserved.*



Filtration for Commercial Office Spaces

NAFA guidelines provide advice on achieving the cleanest air possible based on the design limits of existing HVAC equipment and with consideration of the impact on energy and the environment. Our guidelines are created and updated to collect and supplement existing information. However, we go beyond the “bare minimum,” publishing best practices based on the experience and expertise of our membership, as well as current mandates and research provided by governmental and scientific communities.

For a more complete explanation of principles and techniques found in this guideline, visit www.nafahq.org to purchase the *NAFA Guide to Air Filtration*. If you have any questions or comments about this publication, please contact NAFA Headquarters.

A special thank you to the following member contributors:

Lead author:

Kevin Delahunt, CAFS
BGE Indoor Air Quality Solutions

Committee Chair:

Randy Brannen, CAFS
NCT II Quality Filters, Inc.

Contributors:

Michael Beier, CAFS
Products Unlimited, Inc.

Roberta MacGillivray, CAFS, NCT BGE
Indoor Air Quality Solutions Ltd.

Julie Engelstad, CAFS
Camfil USA, Inc.

Tim Mohan, CAFS Tristate Filter & HVAC
Supplies, Inc.

Keith Jordan
Sanuvox Technologies, Inc

Jay Reese, CAFS
J & BR Associates, LLC

Tom Justice, CAFS, NCT
Zene

Patrick Rosenthal, CAFS
Tex-Air filters

Paula Levasseur, CAFS
LMF Services LLC

George Spottswood, CAFS
Quality Filters, Inc.

About Us

Our Mission:

The National Air Filtration Association (NAFA) mission is to be the global source for expertise, education & best practices in air filtration.

What can NAFA membership do for you?

NAFA brings together air filter and component manufacturers, sales and service companies, and HVAC and indoor air quality companies. By becoming a member, you can:

- Meet with industry thought leaders
- Strengthen your network
- Share best practices
- Receive up to date industry information
- Access professional development, certification and education

Be a part of something bigger

As a NAFA member, you are a part of a support system that shares the common goals of supporting industry growth and creating healthier communities. Following the coronavirus pandemic, we are more aware than ever of the important role that our members play in a well society. We know that our work is important to maintaining healthy, happy communities.

Benefits of Membership

As a member of NAFA, you'll have access to a host of benefits that offer networking, learning, and advertising opportunities. Here are just a few of our most popular benefits:

- Annual conferences and webinars
- Professional development programs (CAFS and NCT Level I & II certification)
- Air Media magazine
- Best practices guidelines
- Clean Air Award recognition program
- Library of resources, manuals, seminars, and training.
- NAFA advertising and sponsorship programs
- Exposure through NAFA social media and a listing on the NAFA website
- NAFA volunteer and leadership opportunities

...and more!

Click [here](#) to become a member today!

CAFS & NCT Certifications

Educate your team
Attract new customers
Be known as a leader in your industry

Now more than ever, customers seek professionals with the credentials for quality assurance and knowledge to ensure that their complex needs will be met. Addressing this concern, NAFA offers two certification programs to increase the level of education and professionalism in the industry.

The NAFA Certified Air Filter Specialist (CAFS) program

CAFS is the first education and certification program offering an extensive examination on the principles, methods and applications of air filtration. It differentiates professionals who have demonstrated a high level of professionalism and a thorough, up-to-date understanding of air filtration technology. The CAFS exam is pass/fail, and is based on the NAFA Guide to Air Filtration.

NAFA Certified Technician (NCT) Program

This open-book exam is based on the NAFA Installation, Operation, and Maintenance of Air Filtration Systems manual. This program was designed to increase the knowledge of technicians, facility managers, and building owners.

Both certifications are renewable on an annual basis pending successful completion of continued education requirements. While the exams are open to members and nonmembers alike, test fees are dramatically reduced for members. To find out more about the cost, study aids, test dates/locations, and requirements, visit the weblinks below.

[CAFS information page](#)

[NCT information page](#)

About This Publication

1

PURPOSE

This best practice establishes air filtration guidelines for the removal of particulate, bioaerosols, and gaseous contaminants for the protection of the air handling equipment and components, as well as providing comfort and a healthy environment for all who work, visit, live and play in these facilities. The recommendations in this guideline are considered by NAFA to be “best practice” in contrast to “minimum standards” as put forth by other organizations. It will serve to provide owners and facility managers with the necessary information to develop effective filtration strategies for their facility’s Indoor Air Quality (IAQ) and Life Safety Programs.

2

SCOPE

This best practice guideline will address the filtration practices associated with the complex systems and applications found in today’s commercial office buildings. It will take into consideration life safety, security, health, comfort, equipment protection and tenant retention as factors involved in the filtration decisions. Per ANSI/ASHRAE Standard 62.1-2019, this guideline will not include recommendations for the removal of cigarette smoke in a commercial building. It will look at operating and maintenance of filtration systems as well as conditions such as renovations, internal construction, and localized exhaust. This document does not address the special requirements for healthcare facilities; a guideline specifically for Healthcare Facilities will be available at a future date.

For the purpose of this Best Practice, we will use ASHRAE’s definition of commercial buildings as found in ANSI/ASHRAE/ ACCA Standard 180-2018 – “Standard Practice for Inspection and Maintenance of Commercial Building HVAC Systems,” “Commercial buildings shall include, but are not limited to, government and educational facilities, healthcare and hospitality facilities, institutional buildings, offices, places of assembly, restaurants, and buildings for retail and wholesale businesses.”

3

BACKGROUND

The quality of air in the built environment has a significant impact on human health and comfort. Poor IAQ can lead to discomfort, ill health, building related illness, absenteeism, and reduced productivity thus making IAQ an important occupational and environmental health issue. The number of complaints related to IAQ has increased with the trend towards tighter sealed buildings, energy conservation, the growing use of synthetic materials, the increase in office equipment (photocopiers, laser printers, 3D printers and computers), cleaning products, outdoor air pollution, and the increased awareness of the public to the symptoms and effects of poor IAQ. Contaminants that present specific problems in commercial office spaces include: plant and animal allergens, gases and odors, bioaerosols (viruses, bacteria, fungal spores) and particles, specifically below 2.5 microns in size (PM2.5). The facility management team of a commercial building must be cognizant of these issues and develop a filtration and IAQ program that meets or exceeds their tenant’s expectations as well as any building certification programs they have adopted. Never before has the task of maintaining occupant comfort and health in a commercial structure been more challenging.

BACKGROUND (CONTINUED)

Although the importance of filtration is often expressed as a key component in an IAQ program, the only mandatory reference to filtration performance is in ANSI/ASHRAE Standard 62.1-2019 “Ventilation for Acceptable Indoor Air Quality”:

- a. MERV of not less than 8 where rated in accordance with ASHRAE Std. 52.2 or
- b. The minimum efficiency within ISO ePM10 where rated in accordance with ISO 16890.

As 9/11 raised the awareness of building security, so too has the Covid-19 crisis heightened the need for air filtration and the importance of Indoor Air Quality. See the special Covid-19 section included in this guidelines for recommendations.

ANSI / ASHRAE STANDARD 62 . 1 VENTILATION FOR ACCEPTABLE INDOOR AIR QUALITY

This standard defines acceptable indoor air quality as: “air in which there are no known contaminants at harmful concentrations as determined by cognizant authorities and with which a substantial majority (80% or more) of the people exposed do not express dissatisfaction.” The standard identifies three procedures for providing acceptable IAQ.

Ventilation Rate Procedure (VRP)

The most commonly used is the Ventilation Rate Procedure (VRP) which prescribes the amount of ventilated air to be delivered to a space based on space type/application, occupancy level, and floor area.

IAQ Procedure (IAQP)

The IAQ Procedure offers an option to the VRP by reducing and controlling the concentration of contaminants through air cleaning to specified levels. The IAQ Procedure can reduce the amount of ventilation air below prescribed levels if it can be demonstrated that the air quality meets the required performance.

Natural Ventilation Procedure (NVP)

The third procedure is the Natural Ventilation Procedure (NVP). The NVP is a prescriptive design procedure in which outdoor air is provided through openings to the outdoors, permitted to be used for any zone in conjunction with mechanical ventilation systems.

“The standard acknowledges that air cleaning along with recirculation is an effective means for controlling levels of contaminants.”

6.1.4.1 Particle Matter

Removal smaller than 10 Micrometers (PM10)

In buildings located in an area where the national standard or guideline for PM10 is exceeded, particle filters or air cleaning devices shall be provided to clean the outdoor air at any location prior to its introduction to occupied spaces. Particulate matter filters or air cleaners shall have either:

- a. a MERV of not less than 8 where rated in accordance with ASHRAE Standard 52.2.
- b. the minimum efficiency within ISO ePM10 where rated in accordance with ISO 16890.

6.1.4.2 Particle Matter Removal smaller than 2.5 Micrometers (PM2.5)

In buildings located in an area where the national standard or guideline for PM2.5 is exceeded, particle filters or air- cleaning devices shall be provided to clean the outdoor air at any location prior to its introduction to occupied spaces. Particulate matter filters or air cleaners shall have either:

- a. a MERV of not less than 11 where rated in accordance with ASHRAE Standard 52.2.
- b. the minimum efficiency within ISO ePM2.5 where rated in accordance with ISO 16890.

The ASHRAE recommendations are a good start but may not address the unique needs associated with today’s modern commercial office buildings.

NAFA Best Practice Recommendations - System Approach

The commercial office buildings of today provide more than just a space for tenants to work. They are small communities that can include restaurants, health clubs, medical clinics, retail shopping, parking garages, living quarters and more. For a facility management team this presents some unique challenges. Specialized mechanical equipment is required for servicing these varied applications and the unique activities associated with them. The following mechanical equipment and applications can be found in some, or all, commercial office buildings.

1

CENTRAL AIR HANDLING UNITS

The Central Air Handling Unit (CAHU) in commercial buildings provides thermal comfort (temperature and humidity), ventilation and the removal of gaseous and particulate contaminants. In many commercial buildings the Central Air Handling Unit is the main mode of supplying conditioned air to tenant spaces. The filtration system is just one component of the system that could contain all, or some, of the following components: heating and cooling coils, humidification systems, fans, dampers and motors.

Central Air Handling Units condition the largest percentage of outside air (OA) entering a building. This necessitates the need to remove a variety of contaminants to maintain the effective operation of the system, and to provide a healthy environment for the occupants of the building. In some instances, the air being returned to the CAHU is more contaminated than the OA requiring the need for particulate, and sometimes, odor/gaseous removal at the unit.

Effective filtration for a CAHU is accomplished with a two-stage approach incorporating a pre-filter of MERV 8 and a final filter of MERV 13 or higher at the prescribed air flow. In some cold weather climates, a summer and winter bank are used with the pre-filter alternating positions depending upon the season while the secondary filter remains in the downstream winter position. In some locations a single filter system is effective, and in this case, we recommend MERV 13 or higher. The decision to use a single stage system versus a two-stage system is based upon particulate load, life cycle costing (LCC), and energy conservation.



Photograph courtesy of Engineered Air

NAFA Best Practice Recommendations - System Approach (continued)

2 ROOFTOP AIR HANDLING UNITS

A Rooftop Air Handling Unit (RAHU) maintains comfort conditions in a zone by providing a constant volume of air that varies according to load. Rooftop units can be the entire source of heating and cooling for a building, or a supplemental system to the existing Heating, Ventilating and Air Conditioning (HVAC) system. To control particulate effectively a rooftop system supplying air to a commercial office building should be designed with a two-stage system of a MERV 8 pre-filter and MERV 13 or higher final filter. A single stage filter system can also be considered, and our recommendation is for MERV 13 or higher filter.



Photograph courtesy of Engineered Air

3 MAKE UP AIR

Make-up air (MUA) equipment is designed to provide ventilation air into a space or replace air exhausted from the building. It may be used to prevent negative pressure within the building or to control the contaminant level in the space. An example of MUA units for commercial use is the parking garage where the units provide replacement outside air when contaminated vehicle air is exhausted.



Photograph courtesy of McQuay International

An MUA unit operates on 100% outside air and a single stage filtration system of MERV 11 or higher is recommended. The area serviced by these systems are typically not tenant occupied areas so the lower MERV filter is acceptable to protect the equipment components of the unit.

4 UNITARY EQUIPMENT

Unitary equipment refers to factory made systems that normally include heat/cool coils, fan, motor, humidification, filtration, and ventilation components. Unitary systems are commonly used as compartmental floor units where return air from the indoor space is mixed with outside air from the central air handling unit to provide conditioned air to the floor. Because the outside air is already filtered at the Central system the compartmental unit traditionally has a single stage filter with a recommendation of MERV 13 or higher. The task for this filter is to remove the contaminants which are generated in the indoor space.



NAFA Best Practice Recommendations - System Approach (continued)

5

ROOM AIR CONDITIONERS , MINI - SPLIT SYSTEM / DUCTLESS SPLIT SYSTEM AND ROOM AIR CONDITIONERS - MINI - SPLIT SYSTEM / DUCTLESS SPLIT SYSTEM / VARIABLE REFRIGERANT FLOW SYSTEM

These units are not intended for air filtration but are used for environmental control. Follow manufacturer's recommended guidelines for filtration.



Photography courtesy of David Lee

6

UNIT VENTILATORS

Unit ventilators are an assembly of elements whose principal function is to heat a space. They are often used in commercial offices to provide an air current for windows to prevent condensation. Components of unit ventilators include a fan, motor, heating element, filter, and an enclosure. No central air is provided to a unit ventilator, so air is taken from the space and conditioned at the unit. A unit ventilator can also be supplied with an outdoor air damper for ventilation. A MERV 8 or higher filter is recommended for this application as most of the air being used has been filtered at the CAHU.



Photograph courtesy of Engineered Air

7

FAN COIL UNITS

Fan coil units are small unitary systems that provide a combination of heating or cooling to condition a space. The units can sometimes be supplied with outdoor dampers for ventilation. In a commercial office building, fan coils are often used to supply conditioned air to areas such as elevator machine rooms, electrical vaults, telecommunication rooms etc. A filter system of MERV 8 or higher is recommended.



Photograph courtesy of McQuay International

NAFA Best Practice Recommendations - System Approach (continued)

8

SELF - CONTAINED UNITS

Self-contained units are typically constant volume heat/cool units. Outside air to meet ventilation requirements is usually provided by a dedicated outside air duct. Multi-tenant office buildings are often served by multiple self-contained units. Recommended filtration is MERV 8 or higher.



9

HEAT PUMPS

Commercial heat pumps are unitary systems that can operate either in heating or cooling mode. Conditioned air is discharged either directly into the zone or into a ducted system. Recommended filtration is MERV 8 or higher.



Photograph courtesy of Carrier Corp.

10

INDUCTION UNITS

Induction Units are used to save space and give temperature control for each room in which they are installed. Induction units are made for handling the different cooling and heating loads in the perimeter areas of larger buildings. They can be used in combination with a central HVAC system or as a stand-alone system recirculating air within the space. Some induction units are capable of bringing in outside air. They are commonly used in hospitals, hotels, apartments, office buildings, schools, and universities. Recommended filtration is MERV 8 or higher.

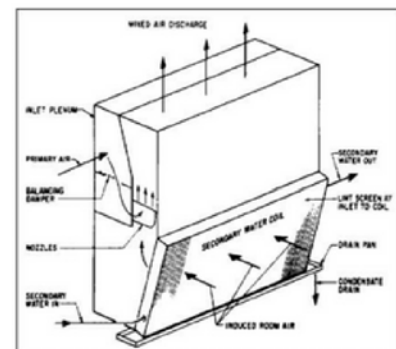

NAFA Best Practice Recommendations - Application Approach

1 LOCALIZED SUPPLY AND EXHAUST

The complexity of operating a commercial office building necessitates the use of special ventilation, cooling, and filtration strategies for operational activities such as: elevator machine rooms, electrical vaults, telecommunication rooms, data rooms, and mechanical equipment. In these applications equipment protection and their ultimate performance are paramount. If the air servicing these spaces is already filtered at the central air handling system, then a MERV 8 or higher filter is recommended. If air is introduced to these applications directly from the outside, a filter system of MERV 13 or higher is recommended.

2 INTERNAL CONSTRUCTION

Renovation and internal construction present a major operational challenge for facility management (FM). The FM team is responsible to maintain building operation while activities such as painting, carpet replacement, and complete floor renovations are taking place. For small renovations on an individual floor consideration must be made for the other tenants on the same floor. In these situations, if possible, the work should be performed during off hours and the contaminants removed at the source. A negative air HEPA fan unit, in conjunction with barrier isolation, will remove the particulate from the area under renovation before it is exhausted outside or returned to the occupied space. Any odors/chemicals created during this process can be addressed with the addition of gas phase filters.

For larger projects, such as a complete floor overhaul, consideration for contaminants returning to the central air handling system will need to be addressed. Additional filters of a MERV 13 or higher should be temporarily installed at each return air grill on the individual floor under construction. The filters should be removed immediately upon completion of the construction and before tenant occupancy. During construction, filters need to be monitored and changed more frequently due to the higher particulate load generated within the space. Any odors created during this process can be addressed with the addition of gas phase filters. For more information see SMACNA – IAQ “Guideline for Occupied Buildings Under Construction.”

3 FOOD PREPARATION

Many commercial office buildings include restaurants, cafeterias, and specialty food and beverage providers. Minimizing food odors within a building requires these areas to be kept under a negative pressure with respect to adjacent spaces. The kitchen air should be exhausted to a location remote from outside air intakes. In many instances the air from food preparation is contaminated with grease, particulate, and odor necessitating the need for removal before exhausting. On all kitchen exhaust hoods, a primary filtration system consisting of a washable baffle filter is installed. In certain situations where exhausting to the outdoors, or exhausting remote from the air intake is not possible some combination of ultraviolet germicidal irradiation lamps (UVGI), high efficiency particulate filters, and gas phase filters are recommended.

NAFA Best Practice Recommendations - Application Approach (continued)

4

BUSINESS PROCESSING CENTER

Rooms designated and dedicated for activities such as printing, photocopying, document shredding, or other specialized office activity may lead to the generation of gaseous, contaminants and particulate contamination. This issue requires special consideration to limit the spread of the contamination to the rest of the building. Air from these locations should be filtered for particulate and gaseous contaminant removal at the source or exhausted directly outdoors. A particulate filter of MERV 13 or higher is recommended along with gas phase filters for gaseous contaminant removal.

5

LIFE SAFETY

Certain buildings and geographic locations may be at more risk for bioterrorism attacks. For information on filtration for these types of buildings, please refer to the NAFA's Position Statement on Bioterrorism, and the ASHRAE document "Risk Management Guidance for Health, Safety, and Environmental Security under Extraordinary Incidents."

Installation, Operation & Maintenance

The following identifies some of the more important factors to consider when installing, operating and maintaining an HVAC Filtration system. As a supplement to manufacturers' guidelines, see NAFA's Installation, Operation and Maintenance of Air Filtration Systems manual or consult a NAFA CAFS.

Installation of Filters & System Integrity

Maintaining integrity of the filter system is vital for the efficacy of the HVAC system and imperative for air filtration performance as unfiltered air by-pass is a key contributor to poor IAQ.

A positively sealed filtration system will prevent unfiltered air bypass, maintain system pressure, and provide consistent filtration system efficiency. After each filter installation, the system must be checked to ensure that there are no possible leaks or gaps in and around the filters. This includes filter frames, fastening devices, caulking and gaskets.

NAFA recommends having a NAFA Certified Air Filtration Specialist (CAFS) inspect the installation for system integrity at least annually.

When changing or modifying the model or design of a filter system consult the manufacturer's specifications of the air handling system. Consideration must be given for:

- Size
- Fit
- Media area
- Airflow rate
- Initial and final pressure drop of the new filter system

Maintenance

A preventive maintenance program should include a monthly inspection of the filtration system. Use the following checklist as a starting point:

- Filters
- Filter hardware
- Fastening devices
- Caulking
- Gaskets
- Ductwork

Removing and replacing damaged or defective filters, filter hardware, gaskets, and duct insulation will keep unfiltered air from bypassing the filter system. Keeping the coils and blower clean and free from dirt and debris will improve airflow, increase system efficiency, reduce electrical consumption, and maintain overall design performance. Scheduled filter maintenance will keep the HVAC system working efficiently with clean, conditioned air and a reduction in contaminant levels.

Additional information regarding maintenance of HVAC and filter systems may be found in the ANSI/ASHRAE/ACCA Standard 180, "Standard Practice for Inspection and Maintenance of Commercial Building HVAC Systems."

Installation, Operation & Maintenance (continued)

Monitoring of Airflow and Pressure Drop

As a filter loads with contaminants the resistance to air flow through the filter increases. This increase is referred to as “pressure drop” or “differential pressure.”

As an example, in a draw-through system, as the filters load and the resistance increases, the fan pressure is lower on the downstream side. Hence the pressure “drop” downstream of the filters.

This drop or differential can be measured with a pressure sensing device such as a manometer or magnehelic gauge. All HVAC units should have a pressure-sensing device installed to accurately monitor the pressure drop across the filter bank. In extreme temperature conditions, a magnehelic gauge is recommended over a manometer. When a filter has exceeded its useful life based on pressure drop or Life Cycle Costing, it should be replaced. Leaving a filter in service after this point may increase operational and energy costs and could damage the HVAC system.

Most molecular filters, over time, will not increase in pressure drop. Some particulate media, when impregnated with sorbent, could increase in pressure drop. This is not indicative of the service life of the sorbent. Service life of a molecular filter is a function of types and concentration of contaminants and filter design. Most manufacturers offer testing services to determine remaining filter service life. It is important to note that as the media life decreases, so does the efficiency of the molecular filter. Molecular filters are often recommended for change out before media is 100% spent.

Filter Service

The servicing of filtration products is a dirty business. It is best practice that service technicians have a safe work environment and use the correct personal protective equipment (PPE). Outer layer clothing should be weather appropriate in line with the climatic conditions. PPE includes:

- Eye protection
- Masks
- Gloves
- Coveralls
- Safety Boots
- Hearing Protection
- Hard Hat



In addition, service technicians should have a good working knowledge of:

- HVAC systems
- Ladder safety
- Confined space entry
- Risk management
- Shut down procedures
- Lock-out procedures



The use of specialized procurement devices (pictured above) should be used for safely adding, and removing product from difficult access points, such as a roof.

Installation, Operation & Maintenance (continued)

Training

The servicing of air filtration products is becoming more technical and requires specialized skills. It is for this reason that NAFA introduced the Certified Technician (NCT) Program in 1999 to increase expertise and professionalism to the air filtration industry. The NCT enables facility managers and building owners the opportunity to certify their employees on all aspects of filtration service and Indoor Air Quality.



For additional information visit the NAFA website: www.nafahq.org or contact a local NAFA member.

Disposal

Particulate filters should be assumed to be contaminated with viable organisms, possibly hazardous in nature, and need to be disposed of in a careful and safe manner. Dispose of spent filter products in a safe manner protecting the HVAC equipment, building occupants, and especially, the technicians performing the work. Spent carbon in molecular filters may sometimes be returned to the manufacturer for reactivation. NAFA recommends that technicians performing the work be certified to NAFA Certified Technicians (NCT) standards.

Summary

This guideline identifies what NAFA considers as the “best practice” recommendation for filtration in Commercial Office Buildings. It looks at both a system and application specific approach to improve indoor air quality and HVAC equipment protection in Commercial Office Buildings. It raises awareness of the filter as one element in the filtration system by emphasizing the importance of the filter hardware, as well as, proper installation and maintenance.

**You care about your employees and your students.
You care about the environment and your community.
You care about the fiscal health of your institution.**

Indoor air quality matters.

KEY RECOMMENDATIONS FOR YOUR HVAC SYSTEM

- Run the HVAC whenever the space is occupied.
- Direct the clean/cleaned air into the breathing zone in each occupied space.
- Return air vents should pull air from the room and not directly from the clean air inlet.
- Maintain temperature and humidity design set points.
- Set the HVAC system to bring in as much outside ventilation air as possible.

KEY RECOMMENDATIONS FOR FILTER MAINTENANCE

- To achieve the recommended MERV 13-equivalent or better levels of performance (which removes $\geq 85\%$ of 1-3 μm particles), a combination of filters/air cleaners can be used.
- Use only air cleaners for which evidence of effectiveness and safety is clear.
- When upgrading filters, carefully monitor to ensure your current system can handle the upgrade (e.g. pressure drop).
- Upgrading both pre-filters and filters may cause unacceptable pressure drop. It may not be necessary to upgrade both.
- Consider using the AHAM Clean Air Delivery Rate (CADR) for sizing air-cleaners for your space.
- Confirm filters are sealed in their frames, preferably with gaskets to prevent filter bypass.
- Personnel changing filters should wear PPE. Dispose of spent filters immediately and in a safe manner.

DID YOU KNOW?

Studies with SARS CoV-1 have shown that toilet flushing can generate airborne droplets and aerosols that could contribute to transmission of pathogens. Remember to:

- Keep toilet room doors closed, even when not in use.
- Encourage putting the toilet seat lid down, if there is one, before flushing.
- Keep bathroom fans running continuously and vent separately, where possible.

Glossary

Air Filter/Air Cleaning: A device used for the removal of particulate or gaseous impurities from the air.

AHU: Air handling unit describes the unit or units supplying a building with conditioned air. It can be described as the lungs of a building.

ANSI: American National Standards Institute – As the voice of the U.S. standards and conformity assessment system, ANSI empowers its members and constituents to strengthen the U.S. marketplace position in the global economy while helping to assure the safety and health of consumers and the protection of the environment.

ASHRAE: American Society of Heating, Refrigerating and Air Conditioning Engineers. ASHRAE is an international organization that sets standards and guidelines for the heating, ventilating, air conditioning, and refrigeration industry.

ACH: Air changes per hour computed by taking the cubic area of a space and dividing by the volume of air per hour supplied to it.

CAFS: Certified Air Filter Specialist accreditation granted by NAFA to those who pass an exam on air filtration.

DOP: Dioctyl Phthalate is a chemical used to challenge HEPA filters. Factory testing involves heating DOP to produce a monodispersed particle challenge and distribution through a Laskin nozzle produces a polydispersed particle challenge.

FPM: Feet per minute describes velocity of air. FPM is always positive and always measured in one direction.

HEPA: High Efficiency Particulate Air filter – describes a filter that achieves a minimum of 99.97% efficiency on 0.3 micrometer particles or similar challenge.

HVAC&R: Heating, Ventilating, Air Conditioning and Refrigeration.

IAQ: Indoor air quality describes the quality of air supplied to an interior space. The goal of IAQ is to provide air that is clean and healthy to building occupants.

In-situ: Translated means “in position.” This refers to measuring a filter installed in a system commonly using cold DOP for HEPA filters to test for leaks or using ambient air and a particle counter to perform ANSI/ASHRAE GP 26.

Life Cycle Costing (LCC): The investigation and valuation of the environmental impacts of air filters.

Makeup Air: Air supplied to a space for the purpose of replacing exhausted air from a space.

MERV: Minimum Efficiency Reporting Value refers to the lowest efficiency of a filter when tested in accordance with ANSI/ASHRAE Standard 52.2 2017.

NAFA®: Registered acronym for the National Air Filtration Association, the trade association for air filter manufacturers and distributors, worldwide.

OSHA: Occupational Safety and Health Administration, the group that is charged with enforcement of health and safety legislation.

PM 2.5: Fine particulate matter (PM2.5) is an air pollutant that is a concern for people’s health when levels in air are high. PM2.5 are tiny particles in the air that reduce visibility and cause the air to appear hazy when levels are elevated.

PPM: Parts per million refers to the concentration of a substance within another substance. One ppm is equivalent to 1 milligram of something per liter of air (mg/l).

Pressure Drop: The resistance of a device to the flow of a fluid through it. The pressure drop of a filter is a measure of its resistance to airflow through it. Resistance is measured in inches water gauge (w.g.) in the inch-pound system. It is measured in pascals in the SI system.

OA: Outdoor air.

Bibliography & Photographs

- ANSI/ASHRAE Standard 62.1 – 2022. Ventilation for Acceptable Indoor Air Quality.
- ANSI/ASHRAE Standard 52.2 – 2017. Method of testing General Ventilation Air Cleaning Devices for Removal Efficiency by Particle Size.
- ANSI/ASHRAE/ACCA Standard 180 – 2018. Standard practice for Inspection and Maintenance of Commercial Building HVAC Systems.
- 2019 ASHRAE Handbook – HVAC Applications.
- 2020 ASHRAE Handbook – HVAC Systems and Equipment.
- 2021 ASHRAE Handbook – Fundamentals.
- “Particle Management for HVAC Systems.” Thomas C. Ottney. ASHRAE Journal July 1993.
- ASHRAE Report of Presidential Ad Hoc Committee for Building Health and Safety under Extraordinary Incidents on Risk Management Guidance for Health, Safety, and Environmental Security under Extraordinary Incidents, 26 January 2003.
- Z204-94 (R1999) Guideline for Managing Indoor Air Quality in office buildings. CSA.
- IAQ and HVAC Workbook. 3rd Edition – D. Jeff Bruton. Guidance notes for the Management of IAQ in Offices and Public Places – IAQ Management Group, Government of Hong Kong.
- “Taking Charge Against the New Threat.” H.E. Barney Burroughs. RSES Journal January 2002.
- NAFA Guide to Air Filtration, National Air Filtration Association.
- Installation, Operation, and Maintenance of Air Filtration Systems, National Air Filtration Association.
- Sheet Metal Air Conditioning Contractors National Association (SMACNA) publication, “IAQ Guidelines for Occupied Buildings Under Construction” 601 N. Fairfax St. Suite 250, Alexandria, VA 22314 Nestrovich, Peter.

PHOTOGRAPHS

- Nestrovich, Peter. “Photo permission Part1” to Kevin Delahunt, 22 March 2011
- Nestrovich, Peter. “Engineered Air Equipment Pictures” to Kevin Delahunt, 22 March 2011
- David Lee, 2011 used under license from Shutterstock.com.

Copyright & Usage

As a global source for expertise, education & best practices in air filtration, we provide these guidelines with one important goal in mind: **To support best practices and ensure the cleanest air possible for our employees, our customers, and our community.**

While the information provided is the property of NAFA and is protected by copyright and intellectual property laws, we strongly encourage the use and dissemination of this information - in print or electronically - to those within our industry.

These guidelines were created through the hard work and care of experts in the industry... your peers. By reading these guidelines you agree not to reproduce, broadcast, or otherwise distribute the information within these guidelines for commercial purposes without the prior written consent of NAFA. If such permissions are granted, you also agree to include in any printed/electronic uses the phrase, "Used with permission of The National Air Filtration Association®."

Disclaimer

The information contained in this guideline is intended for reference purposes only. NAFA has used its best efforts to assure the accuracy of information and industry practices. NAFA encourages the user to work with a NAFA Certified Air Filter Specialist (CAFS), to ensure that these guidelines address user specific equipment and facility needs. Issues regarding health information, including COVID- 19, may be superseded by new developments in the field of industrial hygiene or by new information revealed by experts in science/ medicine. Users are therefore advised to regard these recommendations as general guidelines and to determine whether new information is available.

